

STEEL TUBE
services

TUBE & PROFILE

PRODUCT LIST

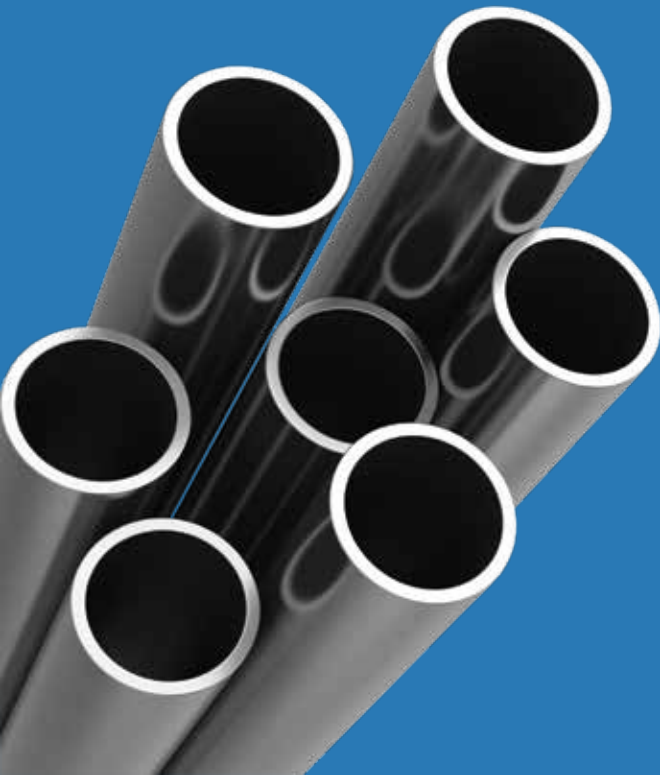

Contact Us

www.steeltubeservices.co.za

+27 (11) 866 1821

Internal Sales Representatives

Bernice Gombert

bernice@steeltubeservices.com

Samantha Menezes

samantham@steeltubeservices.com

Import/Export Coordinator

Megan Robertson

megand@steeltubeservices.com

Sales Manager

Sanjay Singh

sanjays@steeltubeservices.com

General Sales Manager/Buyer

Mohamed Ameen Essat

mohamede@steeltubeservices.com

About Us

Steel Tube Services is a manufacturer and distributor of hot rolled precision, drawn structural tubing. Steel Tube Services is the realisation of the dream of Victor da Silva Snr. who started his career as a qualified Fitter & Turner. After being in the steel industry for 8 years Victor's drive and passion led him to build on the dream of creating a family-built and run business that strives for nothing short of excellence.

We opened our doors in 1991 and for 30 years we have grown the company on the same values that it was started, all those years ago. Our business now offers high-quality steel products as well as services that include: manufacturing, importing, draw-downs, sourcing materials, and custom forming.

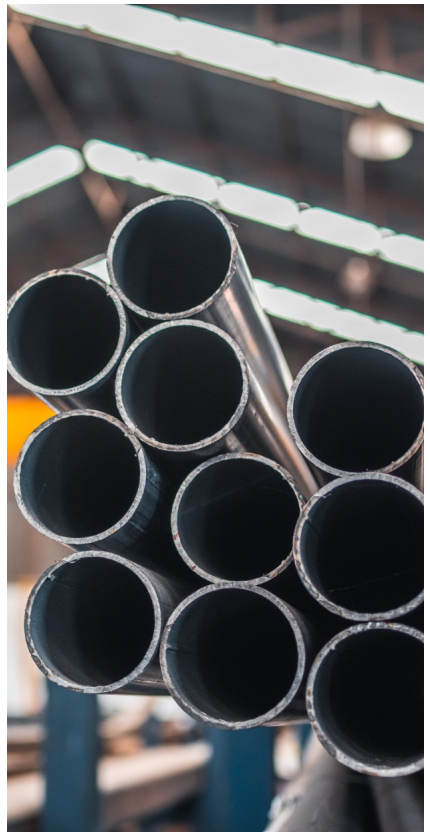

Our Core Values



**Quick
Turnaround
Times**



**Quality Products
and Services**



**Exceeding
Customer
Satisfaction**

Our Services

•Draw Downs

•Custom Forming

•Source Materials

•Imports

•Delivery

OUR PRODUCTS



ROUND TUBING CIRCULAR HOLLOW SECTION

ROUND TUBING	W/T mm	MASS kg / Mtr	MATERIAL GRADE SPECIFICATION
12.7	1.6	0.438	SAE 1008
15.9	1.6	0.563	SAE 1008
	2.0	0.686	SAE 1008
19.1	1.6	0.688	SAE 1008
	2.0	0.840	SAE 1008
21.4	1.6	0.778	
	2.0	0.953	SAE 1008
	2.5	1.158	SAE 1008
	3.0	1.361	SAE 1008
25.4	1.6	0.939	SAE 1008
	2.0	1.154	SAE 1008
	2.5	1.411	SAE 1008
	3.0	1.657	SAE 1008
26.99	1.6	1.002	SAE 1008
	2.0	1.233	SAE 1008
	2.5	1.502	SAE 1008
	3.0	1.768	SAE 1008
31.8	1.6	1.189	SAE 1008
	2.0	1.467	SAE 1008
	2.5	1.817	SAE 1008
	3.0	2.123	SAE 1008
34.13	1.6	1.282	SAE 1008
	2.0	1.585	SAE 1008
	2.5	1.942	SAE 1008
	3.0	2.293	SAE 1008
	4.0	2.969	SAE 1008

ROUND TUBING	W/T mm	MASS kg / Mtr	MATERIAL GRADE SPECIFICATION
38.1	1.6	1.440	SAE 1008
	2.0	1.780	SAE 1008
	2.5	2.192	SAE 1008
	3.0	2.597	SAE 1008/S355
	4.0	3.364	SAE 1008/S355
	4.5	3.729	SAE 1008/S355
42.9	1.6	1.625	SAE 1008
	2.0	2.012	SAE 1008
	2.5	2.484	SAE 1008
	3.0	2.944	SAE 1008/S355
	3.5	3.392	SAE 1008/S355
	4.0	3.827	SAE 1008/S355
48.5	1.6	1.846	SAE 1008
	2.0	2.288	SAE 1008
	2.5	2.830	SAE 1008
	3.0	3.358	SAE 1008/S355
	3.5	3.875	SAE 1008/S355
	4.0	4.366	SAE 1008/S355
	4.5	4.870	SAE 1008/S355
50.8	1.6	1.940	SAE 1008
	2.0	2.406	SAE 1008
	2.5	2.978	SAE 1008
	3.0	3.533	SAE 1008/S355
	3.5	4.083	SAE 1008/S355
	4.0	4.616	SAE 1008/S355
	4.5	5.138	SAE 1008/S355
57.15	1.6	2.191	SAE 1008
	2.0	2.718	SAE 1008
	2.5	3.372	SAE 1008
	3.0	4.003	SAE 1008/S355
	4.0	5.238	SAE 1008/S355
	4.5	5.837	SAE 1008/S355

ROUND TUBING	W/T mm	MASS kg / Mtr	MATERIAL GRADE SPECIFICATION
60.33	1.6	2.317	SAE 1008
	2.0	2.875	SAE 1008
	2.5	3.564	SAE 1008
	3.0	4.224	S 355
	3.5	4.876	S 355
	4.0	5.551	S 355
	4.5	6.193	S 355
	5.0	6.822	S 355
63.5	1.6	2.440	SAE 1008
	2.0	3.031	SAE 1008
	2.5	3.758	SAE 1008
	3.0	4.472	S 355
	3.5	5.174	S 355
	4.0	5.875	S 355
	4.5	6.541	S 355
76.2	1.6	2.942	SAE 1008
	2.0	3.658	SAE 1008
	2.5	4.534	SAE 1008
	3.0	5.416	S 355
	3.5	6.261	S 355
	4.0	7.105	S 355
	4.5	7.939	S 355
	5.0	8.779	S 355
	6.0	10.387	S 355
88.9	2.0	4.286	SAE 1008
	2.5	5.327	SAE 1008
	3.0	6.355	S 355
	3.5	7.371	S 355
	4.0	8.375	S 355
	4.5	9.366	S 355
	5.0	10.345	S 355
	6.0	12.266	S 355

ROUND TUBING	W/T mm	MASS kg / Mtr	MATERIAL GRADE SPECIFICATION
101.6	1.6	3.946	SAE 1008
	2.0	4.908	SAE 1008
	2.5	6.104	SAE 1008
	3.0	7.288	S 355
	3.5	8.460	S 355
	4.0	9.619	S 355
	4.5	10.760	S 355
	5.0	11.911	S 355
	6.0	14.135	S 355
114.3	2.0	5.535	SAE 1008
	2.5	6.893	SAE 1008
	3.0	8.221	S 355
	3.5	9.555	S 355
	4.0	10.880	S 355
	4.5	12.170	S 355
	5.0	13.465	S 355
	6.0	16.011	S 355
127.0	2.0	6.165	SAE 1008
	2.5	7.669	SAE 1008
	3.0	9.166	S 355
	3.5	10.660	S 355
	4.0	12.120	S 355
	4.5	13.590	S 355
	5.0	15.044	S 355
	6.0	17.880	S 355
139.7	3.0	10.110	S 355
	3.5	11.760	S 355
	4.0	13.390	S 355
	4.5	15.000	S 355
	5.0	16.610	S 355
	6.0	19.780	S 355

ROUND TUBING	W/T mm	MASS kg / Mtr	MATERIAL GRADE SPECIFICATION
152.4	2.0	7.418	SAE 1008
	2.5	9.241	SAE 1008
	3.0	11.050	S 355
	3.5	12.850	S 355
	4.0	14.640	S 355
	4.5	16.410	S 355
	5.0	18.180	S 355
	6.0	21.660	S 355
	8.0	28.490	ATSM A106 GRB
	10.0	35.120	ATSM A106 GRB
165.1	3.0	11.990	S 355
	3.5	13.950	S 355
	4.0	15.890	S 355
	4.5	17.810	S 355
	5.0	19.740	S 355
	6.0	23.540	S 355
177.0	3.0	13.000	S 355
	4.0	17.230	S 355
	4.5	19.340	S 355
	6.0	25.217	S 355
190 x 6.1m	8.0	35.900	ERW API 5L GRB
	10.0	44.390	ERW API 5L GRB
193.7	3.0	14.130	S 355
	3.5	16.440	S 355
	4.0	18.530	S 355
	4.5	21.030	S 355
	5.0	23.300	S 355
	6.0	27.820	S 355
204 X 6.1m	3.5	17.310	ERW API 5L GRB
	4.5	22.140	ERW API 5L GRB
	6.0	29.296	ERW API 5L GRB

ROUND TUBING	W/T mm	MASS kg / Mtr	MATERIAL GRADE SPECIFICATION
219.1	3.5	18.600	S 355
	4.0	21.217	S 355
	4.5	23.810	S 355
	6.0	31.530	S 355
	8.0	41.630	SANS 719 ERW X42 / 300WA
	10.0	51.550	SANS 719 ERW X42 / 300WA
273 x 6.1m	4.5	29.800	SANS 719 ERW X42 / 300WA
	6.0	39.510	SANS 719 ERW X42 / 300WA
	8.0	52.290	SANS 719 ERW X42 / 300WA
	10.0	64.870	SANS 719 ERW X42 / 300WA
	12.7	81.540	SANS 719 ERW X42 / 300WA
324 x 6.1m	4.5	35.455	SANS 719 ERW X42 / 300WA
	6.0	47.051	SANS 719 ERW X42 / 300WA
	8.0	62.350	SANS 719 ERW X42 / 300WA
	10.0	77.450	SANS 719 ERW X42 / 300WA
	12.7	97.510	SANS 719 ERW X42 / 300WA
356 x 6.1m	6.0	51.786	SANS 719 ERW X42 / 300WA
406 x 6.1m			
	6.0	59.200	SANS 719 ERW X42 / 300WA

OUR PRODUCTS



SQUARE TUBING SQUARE HOLLOW SECTION

SQUARE TUBING	W/T mm	MASS kg PER Mtr	MATERIAL GRADE SPECIFICATION
12.7 x 12.7	1.6	0.575	SAE 1008
15.9 x 15.9	1.6	0.734	SAE 1008
	2.0	0.900	SAE 1008
19.1 x 19.1	1.6	0.894	SAE 1008
	2.0	109.7	SAE 1008
25.4 x 25.4	1.6	1.212	SAE 1008
	2.0	1.496	SAE 1008
	2.5	1.817	SAE 1008
	3.0	2.164	SAE 1008
30 x 30	1.6	1.440	SAE 1008
	2.0	1.780	SAE 1008
	2.5	2.192	SAE 1008
	3.0	2.597	SAE 1008
	4.0	3.364	SAE 1008
31.8 x 31.8	1.6	1.513	SAE 1008
	2.0	1.894	SAE 1008
	2.5	2.391	SAE 1008
	3.0	2.831	SAE 1008
	4.0	3.364	SAE 1008
40 x 40	1.6	1.940	SAE 1008
	2.0	2.406	SAE 1008
	2.5	2.985	SAE 1008
	3.0	3.533	SAE 1008
	4.0	4.380	SAE 1008
	4.5	4.870	SAE 1008

SQUARE TUBING	W/T mm	MASS kg PER Mtr	MATERIAL GRADE SPECIFICATION
44.5 x 44.5	1.6	2.191	SAE 1008
	2.0	2.718	SAE 1008
	2.5	3.372	SAE 1008
	3.0	4.003	SAE 1008
	4.0	5.248	SAE 1008
50.8 x 50.8	1.6	2.440	SAE 1008
	2.0	3.090	SAE 1008
	2.5	3.833	SAE 1008
	3.0	4.472	S 335
	3.5	5.174	S 335
	4.0	5.875	S 335
	4.5	6.541	S 335
	5.0	7.359	S 335
	6.0	8.680	S 335
60 x 60	1.6	2.942	SAE 1008
	2.0	3.658	SAE 1008
	2.5	4.534	SAE 1008
	3.0	5.416	S 335
	3.5	6.261	S 335
	4.0	7.105	S 335
	4.5	7.939	S 335
	5.0	8.778	S 335
	6.0	10.386	S 335
63.5 x 63.5	1.6	3.090	SAE 1008
	2.0	3.844	SAE 1008
	2.5	4.774	SAE 1008
	3.0	5.691	S 335
	3.5	6.676	S 335
	4.0	7.499	S 335
	4.5	8.371	S 335
	5.0	8.778	S 335
6.0	11.075	S 335	

SQUARE TUBING	W/T mm	MASS kg PER Mtr	MATERIAL GRADE SPECIFICATION
70 x 70	2.0	4.286	SAE 1008
	2.5	5.327	SAE 1008
	3.0	6.355	S 335
	3.5	7.371	S 335
	4.0	8.375	S 335
	4.5	9.366	S 335
	5.0	10.344	S 335
	6.0	12.265	S 335
76.2 x 76.2	1.6	3.710	SAE 1008
	2.0	4.583	SAE 1008
	2.5	5.690	SAE 1008
	3.0	6.801	S 335
76.2 x 76.2	3.5	7.891	S 335
	4.0	8.969	S 335
	4.5	10.034	S 335
	5.0	11.316	S 335
	6.0	13.467	S 335
80 x 80	2.0	4.908	SAE 1008
	2.5	6.104	SAE 1008
	3.0	7.288	S 335
	3.5	8.460	S 335
	4.0	9.619	S 335
	4.5	10.760	S 335
	5.0	11.911	S 335
	6.0	14.135	S 335
90 x 90	2.0	5.534	SAE 1008
	2.5	6.893	SAE 1008
	3.0	8.221	S 335
	3.5	9.555	S 335
	4.0	10.880	S 335
	4.5	12.170	S 335
	5.0	13.465	S 335
	6.0	16.011	S 335

SQUARE TUBING	W/T mm	MASS kg PER Mtr	MATERIAL GRADE SPECIFICATION
100 x 100	2.0	6.165	SAE 1008
	2.5	7.669	SAE 1008
	3.0	9.166	S 335
	3.5	10.660	S 335
	4.0	12.120	S 335
	4.5	13.590	S 335
	5.0	15.044	S 335
	6.0	17.880	S 335
	8.0	23.540	S 335
	10.0	29.930	S 335
110 x 110	3.0	10.110	S 335
	3.5	11.760	S 335
	4.0	13.390	S 335
	4.5	15.000	S 335
	5.0	16.610	S 335
	6.0	19.780	S 335
115 x 115 Round Corners	3.0	10.110	S 335
	3.5	11.760	S 335
	4.0	13.390	S 335
	4.5	15.000	S 335
	5.0	16.610	S 335
	6.0	19.780	S 335
120 x 120	2.0	7.493	SAE 1008
	2.5	9.355	SAE 1088
	3.0	11.050	S 335
	3.5	12.850	S 335
	4.0	14.640	S 335
	4.5	16.140	S 335
	5.0	18.180	S 335
	6.0	21.160	S 335
	8.0	28.410	S 335
	10.0	35.020	S 335

SQUARE TUBING	W/T mm	MASS kg PER Mtr	MATERIAL GRADE SPECIFICATION
127 x 127 Round Corners	3.0	11.050	S 335
	3.5	12.850	S 335
	4.0	14.640	S 335
	4.5	16.140	S 335
	5.0	18.180	S 335
	6.0	21.160	S 335
127 x 127 Square Corners	3.0	11.619	S 335
	3.5	13.513	S 335
	4.0	15.394	S 335
	4.5	17.262	S 335
	5.0	19.119	S 335
	6.0	22.795	S 335
130 x 130	3.0	11.990	S 335
	3.5	13.950	S 335
	4.0	15.890	S 335
	4.5	17.810	S 335
	5.0	19.740	S 335
	6.0	23.540	S 335
133 x 133 Round Corners	3.0	11.990	S 335
	3.5	13.950	S 335
	4.0	15.890	S 335
	4.5	17.810	S 335
	5.0	19.740	S 335
	6.0	23.540	S 335
140 x 140 Round Corners	3.0	11.990	S 335
	3.5	13.950	S 335
	4.0	15.890	S 335
	4.5	17.810	S 335
	5.0	19.740	S 335
	6.0	23.540	S 335

SQUARE TUBING	W/T mm	MASS kg PER Mtr	MATERIAL GRADE SPECIFICATION
150 x 150	3.0	14.130	S 335
	3.5	16.277	S 335
	4.0	18.750	S 335
	4.5	21.030	S 335
	5.0	23.300	S 335
	6.0	27.820	S 335
	8.0	35.900	S 335
	10.0	44.390	S 335
152 x 152	3.0	14.130	S 335
	3.5	16.440	S 335
	4.0	18.530	S 335
	4.5	21.030	S 335
	5.0	23.300	S 335
	6.0	27.820	S 335
165 x 165	3.5	17.830	S 335
	4.0	22.814	S 335
	6.0	30.196	S 335
177.8 x 177.8	3.5	18.600	S 335
	4.5	23.810	S 335
	6.0	31.530	S 335
	8.0	41.630	300 WA
	10.0	51.550	300 WA
180 x 180	3.5	18.600	S 335
	4.5	23.810	S 335
	6.0	31.530	S 335
	8.0	41.630	S 335
	10.0	51.550	S 335
200 x 200	4.5	27.755	S 335
	6.0	36.790	S 335
	8.0	48.658	S 335
	10.0	60.330	S 335

SQUARE TUBING	W/T mm	MASS kg PER Mtr	MATERIAL GRADE SPECIFICATION
225 x 225	4.5	27.755	S 335
	6.0	36.510	S 335
	8.0	52.290	S 335
	10.0	64.870	S 335
250 x 250	4.5	34.820	S 335
	6.0	46.210	S 335
	8.0	61.220	S 335
	10.0	76.030	S 335
260 x 260	4.5	35.460	300 WA
	6.0	47.060	300 WA
	8.0	62.350	300 WA
	10.0	77.450	300 WA
270 x 270	4.5	35.460	300 WA
	6.0	47.060	300 WA
	8.0	63.350	300 WA
300 x 300	4.5	41.890	300 WA
	6.0	51.800	S 335
	8.0	68.670	S 335
	10.0	85.340	S 335

OUR PRODUCTS



RECTANGULAR TUBING RECTANGULAR HOLLOW SECTION

RECTANGULAR TUBING	W/T mm	MASS kg / Mtr	MATERIAL GRADE SPECIFICATION
19.1 x 12.7	1.6	0.688	SAE 1008
25.4 x 12.7	1.6	0.894	SAE 1008
30 x 20	1.6	1.189	SAE 1008
	2.0	1.467	SAE 1008
	2.5	1.817	SAE 1008
	3.0	2.123	SAE 1008
31.8 x 19.1	1.6	1.212	SAE 1008
	2.0	1.496	SAE 1008
	2.5	1.817	SAE 1008
	3.0	2.123	SAE 1008
38.1 x 19.1	1.6	1.435	SAE 1008
	2.0	1.78	SAE 1008
	2.5	2.192	SAE 1008
	3.0	2.79	SAE 1008
38.1 x 25.4	1.6	1.531	SAE 1008
	2.0	1.894	SAE 1008
	2.5	2.390	SAE 1008
	3.0	2.760	SAE 1008
	4.0	3.364	SAE 1008
40.0 x 15.0	1.6	1.282	SAE 1008
	2.0	1.578	SAE 1008
	2.5	1.942	SAE 1008
	3.0	2.293	SAE 1008

RECTANGULAR TUBING	W/T mm	MASS kg / Mtr	MATERIAL GRADE SPECIFICATION
40.0 x 20.0	1.6	1.440	SAE 1008
	2.0	1.780	SAE 1008
	2.5	2.192	SAE 1008
	3.0	2.597	SAE 1008
	4.0	3.364	SAE 1008
44.5 x 19.1	1.6	1.625	SAE 1008
	2.0	2.012	SAE 1008
	2.5	2.484	SAE 1008
	3.0	2.944	SAE 1008
	4.0	3.827	SAE 1008
44.5 x 31.8	1.6	1.846	SAE 1008
	2.0	2.288	SAE 1008
	2.5	2.830	SAE 1008
44.5 x 31.8	3.0	3.358	SAE 1008
	4.0	4.380	SAE 1008
	4.5	4.870	SAE 1008
50 x 20	1.6	1.690	SAE 1008
	2.0	2.096	SAE 1008
50.0 x 30.0	1.6	1.940	SAE 1008
	2.0	2.406	SAE 1008
	2.5	2.985	SAE 1008
	3.0	3.533	SAE 1008
	4.0	4.629	SAE 1008
	4.5	5.152	SAE 1008
50.8 x 25.4	1.6	1.850	SAE 1008
	2.0	2.293	SAE 1008
	2.5	2.803	SAE 1008
	3.0	3.326	SAE 1008
	4.0	4.380	SAE 1008
	4.5	4.870	SAE 1008

RECTANGULAR TUBING	W/T mm	MASS kg / Mtr	MATERIAL GRADE SPECIFICATION
50.8 x 38.1	1.6	2.190	SAE 1008
	2.0	2.718	SAE 1008
	2.5	3.366	SAE 1008
	3.0	4.003	SAE 1008
50.0 x 40.0	1.6	2.191	SAE 1008
	2.0	2.718	SAE 1008
	2.5	3.378	SAE 1008
	3.0	4.003	SAE 1008
	4.0	5.248	SAE 1008
57.2 x 19.1	1.6	1.846	SAE 1008
	2.0	2.288	SAE 1008
	2.5	2.830	SAE 1008
	3.0	3.358	SAE 1008
	4.0	4.380	SAE 1008
	4.5	4.870	SAE 1008
60.0 x 20.0	1.6	1.940	SAE 1008
	2.0	2.406	SAE 1008
	2.5	2.985	SAE 1008
	3.0	3.533	SAE 1008
	4.0	4.380	SAE 1008
	4.5	4.870	SAE 1008
60.0 x 30.0	1.6	2.191	SAE 1008
	2.0	2.718	SAE 1008
	2.5	3.372	SAE 1008
	3.0	4.003	SAE 1008
60.0 x 40.0	1.6	2.440	SAE 1008
	2.0	3.031	SAE 1008
	2.5	3.758	SAE 1008
	3.0	4.472	S 355
	3.5	5.174	S 355
	4.0	5.875	S 355
	4.5	6.541	S 355

RECTANGULAR TUBING	W/T mm	MASS kg / Mtr	MATERIAL GRADE SPECIFICATION
63.5 x 12.7	1.6	1.846	SAE 1008
	2.0	2.288	SAE 1008
	2.5	2.830	SAE 1008
	3.0	3.358	SAE 1008
	4.0	4.380	SAE 1008
	4.5	4.870	SAE 1008
63.5 x 25.4	1.6	2.191	SAE 1008
	2.0	2.718	SAE 1008
	2.5	3.372	SAE 1008
	3.0	4.003	S 355
	4.0	5.248	S 355
63.5 x 38.1	1.6	2.440	SAE 1008
	2.0	3.031	SAE 1008
	2.5	3.758	SAE 1008
	3.0	4.472	S 355
	3.5	5.174	S 355
	4.0	5.875	S 355
	4.5	6.541	S 355
70.0 x 20.0	1.6	2.191	SAE 1008
	2.0	2.718	SAE 1008
	2.5	3.372	SAE 1008
	3.0	4.003	SAE 1008
76.2 x 25.4	1.6	2.440	SAE 1008
	2.0	3.031	SAE 1008
	2.5	3.758	SAE 1008
	3.0	4.472	S 355
	3.5	5.174	S 355
	4.0	5.875	S 355
	4.5	6.541	S 355

RECTANGULAR TUBING	W/T mm	MASS kg / Mtr	MATERIAL GRADE SPECIFICATION
76.2 x 38.1	1.6	2.817	SAE 1008
	2.0	3.501	SAE 1008
	2.5	4.346	SAE 1008
	3.0	5.178	S 355
	3.5	5.998	S 355
	4.0	6.782	S 355
	4.5	7.581	S 355
76.2 x 50.8	1.6	3.090	SAE 1008
	2.0	3.844	SAE 1008
	2.5	4.774	SAE 1008
	3.0	5.691	S 355
	3.5	6.597	S 355
	4.0	7.499	S 355
	4.5	8.371	S 355
80.0 x 40.0	1.6	2.942	SAE 1008
	2.0	3.658	SAE 1008
	2.5	4.534	SAE 1008
	3.0	5.416	S 355
	3.5	6.261	S 355
	4.0	7.105	S 355
	4.5	7.939	S 355
	5.0	8.779	S 355
	6.0	10.416	S 355
80.0 x 60.0	2.0	4.286	SAE 1008
	2.5	5.327	SAE 1008
	3.0	6.355	S 355
	3.5	7.371	S 355
	4.0	8.375	S 355
	4.5	9.366	S 355
	5.0	10.345	S 355
	6.0	12.299	S 355

RECTANGULAR TUBING	W/T mm	MASS kg / Mtr	MATERIAL GRADE SPECIFICATION
90.0 x 50.0	2.0	4.286	SAE 1008
	2.5	5.327	SAE 1008
	3.0	6.355	S 355
	3.5	7.371	S 355
	4.0	8.375	S 355
	4.5	9.366	S 355
	5.0	10.345	S 355
	6.0	12.299	S 355
90.0 x 60.0	2.0	4.588	SAE 1008
	2.5	5.705	SAE 1008
	3.0	6.808	S 355
	3.5	7.901	S 355
	4.0	8.978	S 355
	4.5	10.045	S 355
	5.0	11.348	S 355
	6.0	13.470	S 355
100.0 x 40.0	2.0	4.286	SAE 1008
	2.5	5.327	SAE 1008
	3.0	6.355	S 355
	3.5	7.371	S 355
	4.0	8.735	S 355
	4.5	9.366	S 355
	5.0	10.345	S 355
	6.0	12.299	S 355
100.0 x 50.0	1.6	3.710	SAE 1008
	2.0	4.583	SAE 1008
	2.5	5.690	SAE 1008
	3.0	6.801	S 355
	3.5	7.891	S 355
	4.0	8.969	S 355
	4.5	10.034	S 355
	5.0	11.316	S 355
6.0	13.327	S 355	

RECTANGULAR TUBING	W/T mm	MASS kg / Mtr	MATERIAL GRADE SPECIFICATION
100.0 x 60.0	2.0	4.908	SAE 1008
	2.5	6.104	SAE 1008
	3.0	7.288	S 355
	3.5	8.460	S 355
	4.0	9.619	S 355
	4.5	10.760	S 355
	5.0	11.911	S 355
	6.0	14.135	S 355
100 x 63.5	2.0	4.908	SAE 1008
	2.5	6.104	SAE 1008
100 x 63.5	3.0	7.288	S 355
	3.5	8.460	S 355
	4.0	9.619	S 355
	4.5	10.760	S 355
	5.0	11.911	S 355
	6.0	14.135	S 355
100.0 x 75.0	2.0	5.534	SAE 1008
	2.5	6.893	SAE 1008
	3.0	8.221	S 355
	3.5	9.555	S 355
	4.0	10.880	S 355
	4.5	12.170	S 355
	5.0	13.465	S 355
	6.0	16.011	S 355
100.0 x 80.0	2.0	5.534	SAE 1008
	2.5	6.893	SAE 1008
	3.0	8.221	S 355
	3.5	9.555	S 355
	4.0	10.880	S 355
	4.5	12.170	S 355
	5.0	13.465	S 355
	6.0	16.011	S 355

RECTANGULAR TUBING	W/T mm	MASS kg / Mtr	MATERIAL GRADE SPECIFICATION
120.0 x 40.0	2.0	4.908	SAE 1008
	2.5	6.104	SAE 1008
	3.0	7.288	S 355
	3.5	8.460	S 355
	4.0	9.619	S 355
	4.5	10.760	S 355
	5.0	11.911	S 355
	6.0	14.135	S 355
120.0 x 60.0	2.0	5.534	SAE 1008
	2.5	6.893	SAE 1008
	3.0	8.221	S 355
	3.5	9.555	S 355
	4.0	10.760	S 355
	4.5	12.170	S 355
	5.0	13.465	S 355
	6.0	16.011	S 355
120.0 x 80.0	2.0	6.165	SAE 1008
	2.5	7.669	SAE 1008
	3.0	9.166	S 355
	3.5	10.660	S 355
120.0 x 80.0	4.0	12.120	S 355
	4.5	13.590	S 355
	5.0	15.044	S 355
	6.0	17.880	S 355
127.0 x 63.5	2.0	5.534	SAE 1008
	2.5	6.893	SAE 1008
	3.0	8.221	S 355
	3.5	9.505	S 355
	4.0	10.880	S 355
	4.5	12.170	S 355
	5.0	13.465	S 355
	6.0	16.011	S 355

RECTANGULAR TUBING	W/T mm	MASS kg / Mtr	MATERIAL GRADE SPECIFICATION
127.0 x 76.2	2.0	6.165	SAE 1008
	2.5	7.669	SAE 1008
	3.0	9.166	S 355
	3.5	10.660	S 355
	4.0	12.120	S 355
	4.5	13.590	S 355
	5.0	15.044	S 355
	6.0	17.880	S 355
120.0 x 101.6	3.0	10.110	SAE 1008
	3.5	11.760	SAE 1008
	4.0	13.390	S 355
	4.5	15.000	S 355
	5.0	16.610	S 355
	6.0	19.780	S 355
130.0 x 50.0	2.0	5.534	SAE 1008
	2.5	6.893	SAE 1008
	3.0	8.221	S 355
	3.5	9.555	S 355
	4.0	10.880	S 355
	4.5	12.170	S 355
	5.0	13.465	S 355
	6.0	16.011	S 355
140.0 x 80.0	3.0	10.110	S 355
	3.5	11.760	S 355
	4.0	13.390	S 355
	4.5	15.000	S 355
	5.0	16.610	S 355
	6.0	19.780	S 355
150.0 x 50.0	2.0	6.165	SAE 1008
	2.5	7.669	SAE 1008

RECTANGULAR TUBING	W/T mm	MASS kg / Mtr	MATERIAL GRADE SPECIFICATION
150.0 x 50.0	3.0	9.166	S 355
	3.5	10.660	S 355
	4.0	12.120	S 355
	4.5	13.590	S 355
	5.0	15.044	S 355
	6.0	17.880	S 355
150.0 x 75.0	3.0	10.110	S 355
	3.5	11.760	S 355
	4.0	13.390	S 355
	4.5	15.000	S 355
	5.0	16.610	S 355
	6.0	19.780	S 355
150.0 x 100.0 Round Corners	3.0	11.050	S 355
	3.5	12.850	S 355
	4.0	14.640	S 355
	4.5	16.410	S 355
	5.0	18.180	S 355
	6.0	21.660	S 355
150.0 x 100.0 Square Corners	3.0	11.619	S 355
	3.5	13.513	S 355
	4.0	15.394	S 355
	4.5	17.262	S 355
	5.0	19.119	S 355
	6.0	22.795	S 355
	8.0	29.815	300 WA
	10.0	36.743	300 WA

RECTANGULAR TUBING	W/T mm	MASS kg / Mtr	MATERIAL GRADE SPECIFICATION
150.0 x 115.0	3.0	11.990	S 355
	3.5	13.950	S 355
	4.0	15.890	S 355
	4.5	17.810	S 355
	5.0	19.740	S 355
	6.0	23.540	S 355
150.0 x 120.0 Round Corners	3.0	11.990	S 355
	3.5	13.950	S 355
	4.0	15.890	S 355
	4.5	17.180	S 355
	5.0	19.740	S 355
	6.0	23.540	S 355
150.0 x 127.0 Round Corners	3.0	11.990	S 355
	3.5	13.950	S 355
	4.0	15.890	S 355
150.0 x 127.0 Round Corners	4.5	17.810	S 355
	5.0	19.740	S 355
	6.0	23.540	S 355
160.0 x 80.0	3.0	11.050	S 355
	3.5	12.850	S 355
	4.0	14.640	S 355
	4.5	16.410	S 355
	5.0	18.180	S 355
	6.0	21.660	S 355
	8.0	28.410	300 WA
	10.0	31.940	300 WA

RECTANGULAR TUBING	W/T mm	MASS kg / Mtr	MATERIAL GRADE SPECIFICATION
160.0 x 90.0	3.0	11.619	S 355
	3.5	13.513	S 355
	4.0	15.394	S 355
	4.5	17.262	S 355
	5.0	19.119	S 355
	6.0	22.795	S 355
160.0 x 100.0	3.0	11.990	S 355
	3.5	13.950	S 355
	4.0	15.890	S 355
	4.5	17.810	S 355
	5.0	19.740	S 355
	6.0	23.540	S 355
165.1 x 101.6	3.0	11.990	S 355
	3.5	13.950	S 355
	4.0	15.890	S 355
	4.5	17.810	S 355
	5.0	19.740	S 355
	6.0	23.540	S 355
177.8 x 90.0	3.0	11.990	S 355
	3.5	13.950	S 355
	4.0	15.890	S 355
	4.5	17.810	S 355
	5.0	19.740	S 355
	6.0	23.540	S 355
177.8 x 127.0	3.0	14.130	S 355
	3.5	16.440	S 355
	4.0	18.530	S 355
	4.5	21.030	S 355
	5.0	23.300	S 355
	6.0	27.820	S 355

RECTANGULAR TUBING	W/T mm	MASS kg / Mtr	MATERIAL GRADE SPECIFICATION
180.0 x 60.0	3.0	17.810	S 355
	3.5	12.850	S 355
	4.0	14.640	S 355
	4.5	16.410	S 355
	5.0	18.180	S 355
	6.0	21.660	S 355
190.5 x 76.2	3.0	11.990	S 355
	3.5	13.950	S 355
	4.0	15.890	S 355
	4.5	17.810	S 355
	5.0	19.740	S 355
	6.0	23.540	S 355
200.0 x 100.0	3.0	15.980	S 355
	3.5	18.600	S 355
	4.5	23.810	S 355
	6.0	31.530	S 355
	8.0	41.630	300 WA
	10.0	51.550	300 WA
203.0 x 102.0	3.0	14.130	S 355
	3.5	16.440	S 355
	4.0	18.530	S 355
	4.5	21.030	S 355
	5.0	23.300	S 355
	6.0	27.820	S 355
	8.0	35.900	300 WA
	10.0	44.390	300 WA
230.0 x 127.0	3.5	18.600	S 355
	4.5	23.810	S 355
	6.0	31.530	S 355
	8.0	41.630	300 WA
	10.0	51.550	300 WA

RECTANGULAR TUBING	W/T mm	MASS kg / Mtr	MATERIAL GRADE SPECIFICATION
230.0 x 177.8	4.5	27.755	300 WA
	6.0	36.709	300 WA
250.0 x 100.0	3.5	18.600	S 355
	4.5	23.810	S 355
	6.0	31.530	S 355
	8.0	41.630	300 WA
	10.0	51.550	300 WA
250.0 x 150.0 Round Corners	4.5	26.577	300 WA
	6.0	35.214	300 WA
	8.0	46.560	300 WA
	10.0	57.700	300 WA
250.0 x 150.0 Square Corners	4.5	27.577	300 WA
	6.0	36.709	300 WA
	8.0	48.650	300 WA
	10.0	60.330	300 WA
250.0 x 180.0	4.5	29.800	300 WA
	6.0	39.510	300 WA
	8.0	52.290	300 WA
260.0 x 190.0	4.5	29.800	300 WA
	6.0	39.510	300 WA
	8.0	52.290	300 WA
270.0 x 180.0	4.5	29.800	300 WA
	6.0	39.150	300 WA
	8.0	52.290	300 WA
280.0 x 150.0	4.5	29.800	300 WA
	6.0	39.150	300 WA
	8.0	52.290	300 WA

RECTANGULAR TUBING	W/T mm	MASS kg / Mtr	MATERIAL GRADE SPECIFICATION
280.0 x 170.0	4.5	29.800	300 WA
	6.0	39.150	300 WA
	8.0	52.290	300 WA
290.0 x 160.0	4.5	29.800	300 WA
	6.0	39.150	300 WA
	8.0	52.290	300 WA
300.0 x 200.0	4.5	34.803	300 WA
	6.0	46.182	300 WA
300.0 x 220.0	4.5	35.460	300 WA
	6.0	47.051	300 WA
	8.0	62.350	300 WA
300.0 x 240.0	4.5	35.460	300 WA
	6.0	47.051	300 WA
	8.0	62.350	300 WA

Seamless Steel Pipes – Pipe Schedule Chart
(O.D. and wall in mm)

Outside Diameter OD	Nom Bore NB	Schedule 10	Schedule 20	Schedule 30	STD	Schedule 40	Schedule 60	Extra Strong	Schedule 80	Schedule 100	Schedule 120	Schedule 140	Schedule 160	XX Strong
		w/t mm	w/t mm	w/t mm	w/t mm	w/t mm	w/t mm	w/t mm	w/t mm	w/t mm	w/t mm	w/t mm	w/t mm	w/t mm
10.3	-	1.24	-	1.45	1.73	1.73	-	2.41	2.41	-	-	-	-	-
13.7	6	1.65	-	1.85	2.24	2.24	-	3.02	3.02	-	-	-	-	-
17.1	10	1.65	-	1.85	2.31	2.31	-	3.2	3.2	-	-	-	-	-
21.34	15	2.11	-	2.41	2.77	2.77	-	3.73	3.73	-	-	-	4.77	7.47
26.67	20	2.11	-	2.41	2.87	2.87	-	3.91	3.91	-	-	-	5.56	7.82
33.4	25	2.77	-	2.9	3.38	3.38	-	4.55	4.55	-	-	-	6.35	9.09
42.16	32	2.77	-	2.97	3.56	3.56	-	4.85	4.85	-	-	-	6.35	9.7
48.26	40	2.77	-	3.18	3.68	3.68	-	5.08	5.08	-	-	-	7.14	10.16
60.32	50	2.77	-	3.18	3.91	3.91	-	5.54	5.54	-	-	-	8.74	11.07
73.02	65	3.05	-	4.78	5.16	5.16	-	7.01	7.01	-	-	-	9.52	14.02
88.9	80	3.05	-	4.78	5.49	5.49	-	7.62	7.62	-	-	-	11.12	15.24
101.6	90	3.05	-	4.78	5.74	5.74	-	8.08	8.08	-	-	-	-	16.15

Outside Diameter OD	Nom Bore NB	Schedule 10	Schedule 20	Schedule 30	STD	Schedule 40	Schedule 60	Extra Strong	Schedule 80	Schedule 100	Schedule 120	Schedule 140	Schedule 160	XX Strong
		w/t mm	w/t mm	w/t mm	w/t mm	w/t mm	w/t mm	w/t mm	w/t mm	w/t mm	w/t mm	w/t mm	w/t mm	w/t mm
114.3	100	3.05	-	4.78	6.02	6.02	-	8.56	8.56	-	11.12	-	13.49	17.12
141.3	125	3.4	-	-	6.55	6.55	-	9.52	9.52	-	12.7	-	15.87	19.05
168.3	150	3.4	-	-	7.11	7.11	-	10.97	10.97	-	14.27	-	18.26	21.95
219.1	200	3.76	6.35	7.04	8.18	8.18	10.31	12.7	12.7	15.08	18.26	20.63	23.01	22.22
273	250	4.19	6.35	7.8	9.27	9.27	12.7	12.7	15.08	18.26	21.44	25.4	28.57	25.4
323.9	300	4.57	6.35	8.38	9.52	10.31	14.27	12.7	17.47	21.44	25.4	28.57	33.32	25.4
355.6	350	6.35	7.92	9.53	9.52	11.12	15.09	12.7	19.05	23.82	27.79	31.75	35.71	-
406.4	400	6.35	7.92	9.53	9.52	12.7	16.66	12.7	21.44	26.19	30.96	36.52	40.49	-
457.2	450	6.35	7.92	11.3	9.52	14.27	19.05	12.7	23.82	29.36	34.92	39.67	45.24	-
508	500	6.35	9.53	12.7	9.52	15.08	20.62	12.7	26.19	32.54	38.1	44.45	50.01	-
558.8	550	6.35	9.53	12.7	9.52	15.87	22.22	12.7	28.57	34.92	41.27	47.62	53.97	-
609.6	600	6.35	9.53	12.7	9.52	17.47	24.61	12.7	30.96	38.89	46.02	52.37	59.54	-
660.4	650	7.92	12.7	-	9.52	-	-	12.7	-	-	-	-	-	-
711.2	700	7.92	12.7	15.88	9.52	-	-	12.7	-	-	-	-	-	-
762	750	7.92	12.7	15.88	9.52	-	-	12.7	-	-	-	-	-	-
812.8	800	7.92	12.7	15.88	9.52	17.47	-	12.7	-	-	-	-	-	-
863.6	850	7.92	12.7	15.88	9.52	17.47	-	12.7	-	-	-	-	-	-
914.4	900	7.92	12.7	15.88	9.52	19.05	-	12.7	-	-	-	-	-	-
1016	1000	-	-	-	9.53	-	-	12.7	-	-	-	-	-	-

CLOSED PROFILES

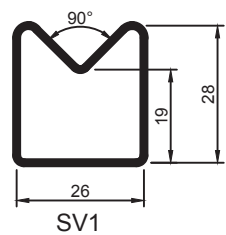
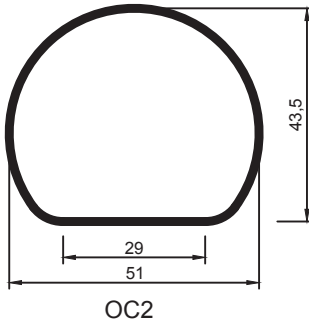
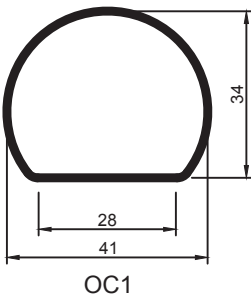
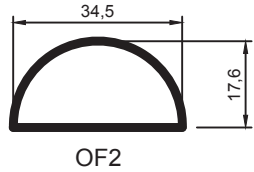
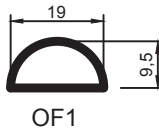
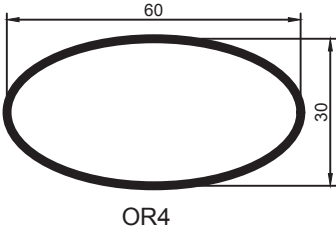
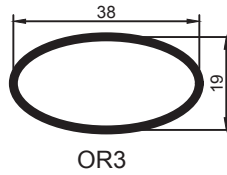
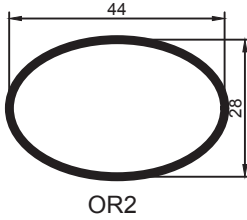
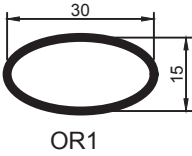
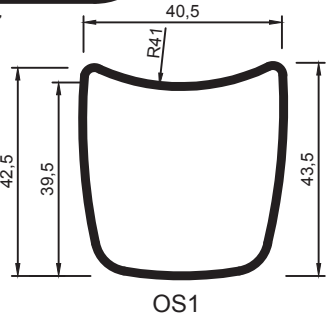
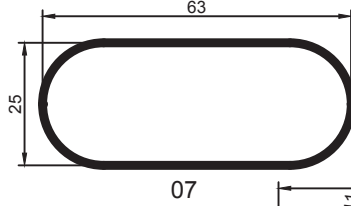
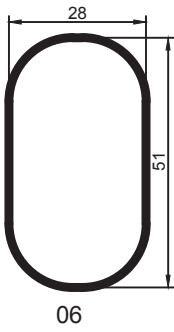
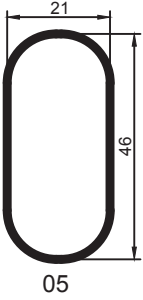
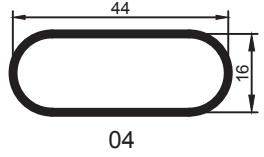
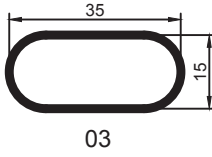
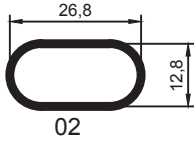
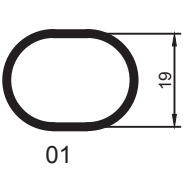

CLOSED PROFILES

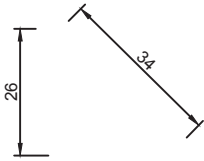

R1

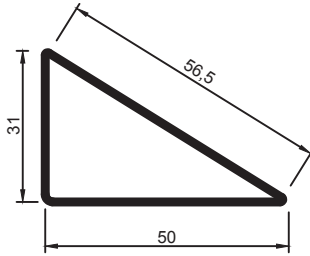

R2

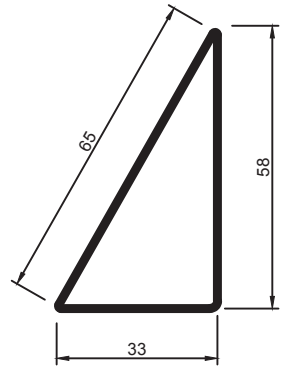

R3

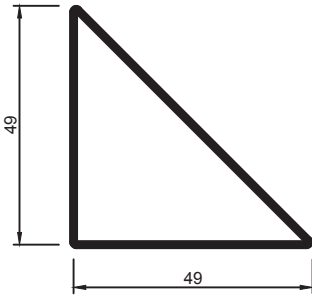

R4

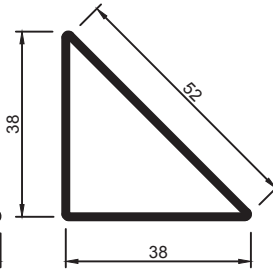

R5

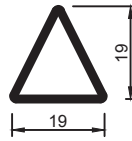

RT1

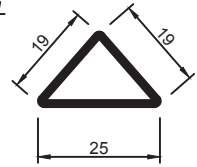

RT2

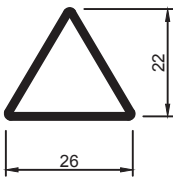

RT3

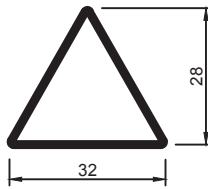

RT4

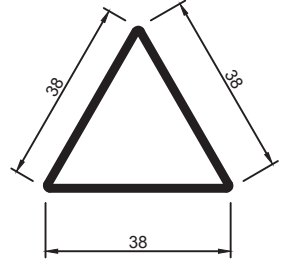

RT5

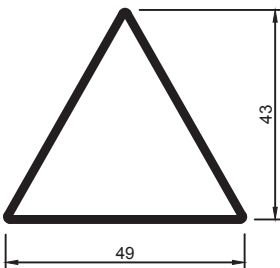

RT5

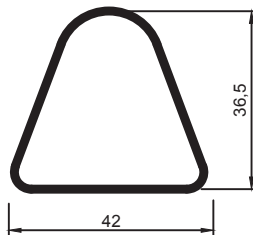

RC1

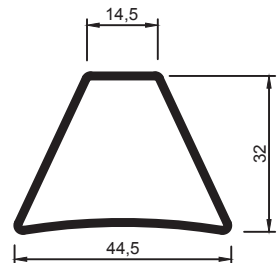

RF1

CLOSED PROFILES

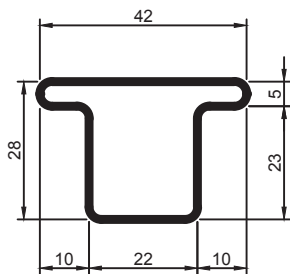

T1

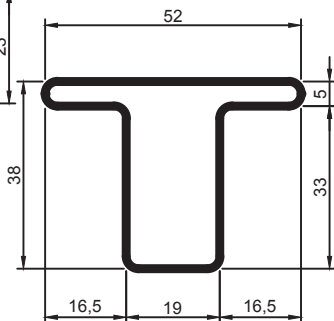

T2

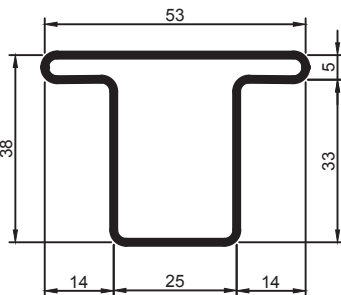

T3

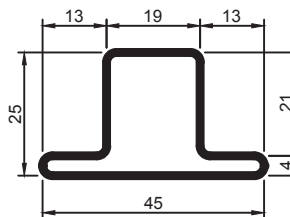

T4

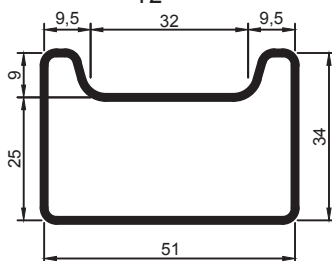

RL1

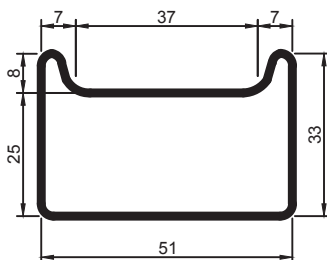

RL2

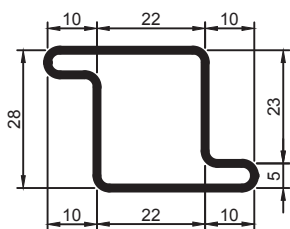

S1

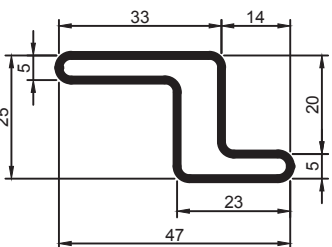

S2

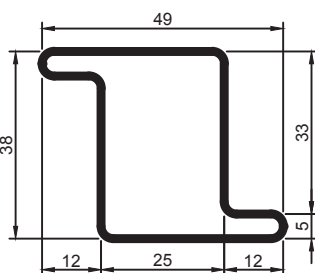

S3

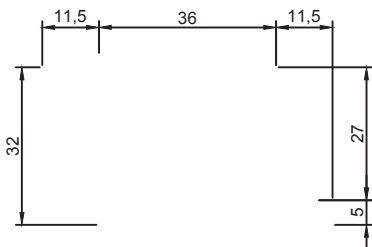

S4

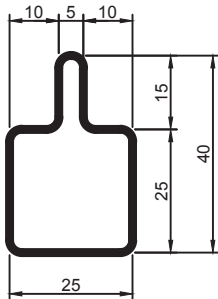

SL1

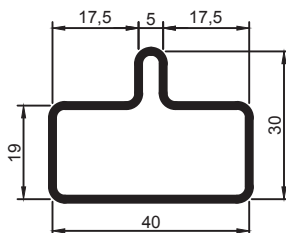

SL2

CLOSED PROFILES

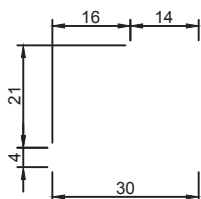

L1

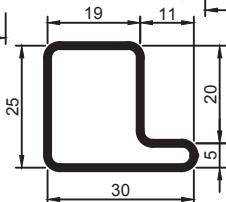

L2

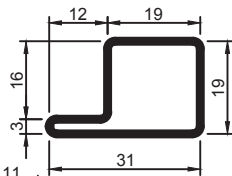

L3

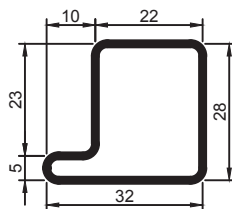

L4

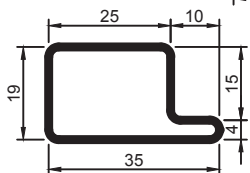

L5

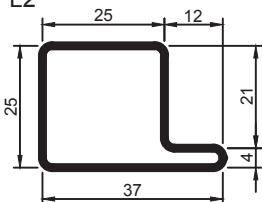

L6

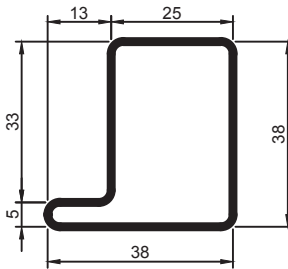

L7

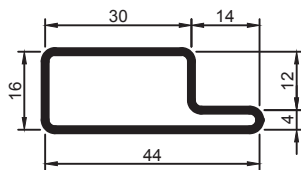

L9

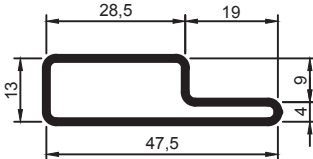

L10

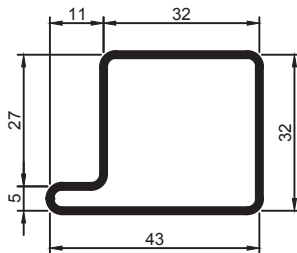

L8

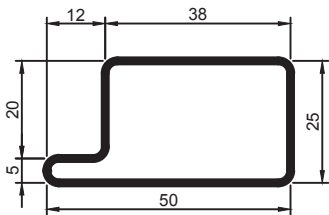

L12

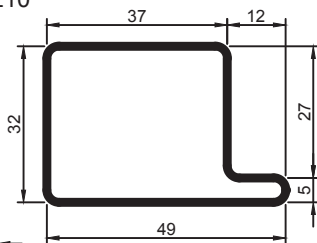

L11

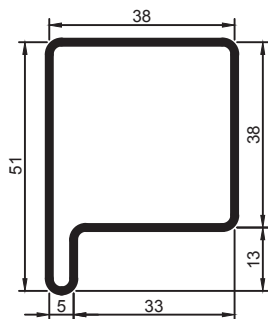

L13

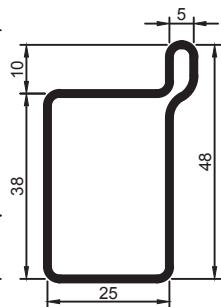

LR1

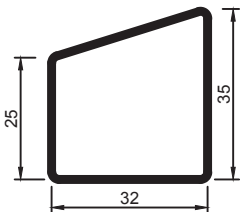

RA1

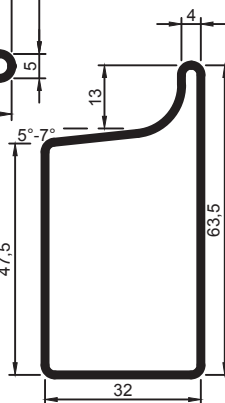

LR2

Non-Standard Items

PLEASE NOTE: All non standard items are
subject to availability

ROUND TUBING	W/T mm	MASS kg / Mtr	MATERIAL GRADE SPECIFICATION
356 x 6.1m	4.5	39.010	SANS 719 ERW X42 / 300WA
	8.0	68.670	SANS 719 ERW X42 / 300WA
	10.0	85.340	SANS 719 ERW X42 / 300WA
	12.7	107.540	SANS 719 ERW X42 / 300WA
406 x 6.1m	4.5	44.560	SANS 719 ERW X42 / 300WA
	8.0	78.530	SANS 719 ERW X42 / 300WA
	10.0	97.654	SANS 719 ERW X42 / 300WA
	12.7	123.200	SANS 719 ERW X42 / 300WA
457 x 6.1m	4.5	50.220	SANS 719 ERW X42 / 300WA
	6.0	66.740	SANS 719 ERW X42 / 300WA
	8.0	88.600	SANS 719 ERW X42 / 300WA
	10.0	110.250	SANS 719 ERW X42 / 300WA
	12.7	139.170	SANS 719 ERW X42 / 300WA

ROUND TUBING	W/T mm	MASS kg / Mtr	MATERIAL GRADE SPECIFICATION
610 x 6.1m	4.5	78.420	G5BG +% 9FK L (' \$K 5
	6.0	104.330	G5BG +% 9FK L (' \$K 5
	8.0	138.720	G5BG +% 9FK L (' \$K 5
	10.0	172.900	G5BG +% 9FK L (' \$K 5
711 x 6.1m	4.5	78.420	G5BG +% GD-F 5@L (' \$K 5
	6.0	104.330	G5BG +% GD-F 5@L (' \$K 5
	8.0	138.720	SANS 719 SPIRAL X42 / 300WA
	10.0	147.990	SANS 719 SPIRAL X42 / 300WA
762 x 6.1m	6.0	111.880	SANS 719 SPIRAL X42 / 300WA
	8.0	148.780	SANS 719 SPIRAL X42 / 300WA
	10.0	185.480	SANS 719 SPIRAL X42 / 300WA
813 x 6.1m	6.0	119.430	SANS 719 SPIRAL X42 / 300WA
	8.0	158.840	SANS 719 SPIRAL X42 / 300WA
	10.0	198.060	SANS 719 SPIRAL X42 / 300WA
914 x 6.1m	6.0	134.370	SANS 719 SPIRAL X42 / 300WA
	8.0	178.770	SANS 719 SPIRAL X42 / 300WA
	10.0	222.970	SANS 719 SPIRAL X42 / 300WA
1016 x 6.1m	6.0	149.470	SANS 719 SPIRAL X42 / 300WA
	8.0	198.900	SANS 719 SPIRAL X42 / 300WA
	10.0	248.130	SANS 719 SPIRAL X42 / 300WA

5 Jurie Street, Alrode, 1451
Tel:011 866 1821
www.steeltubeservices.co.za
enquiries@steeltubeservices.com